

BACnet VAV Actuator Installation Manual	IM 1037
	Group: Controls
	Part Number: IM 1037
	Date: 3/4/2010
	Supersedes: New

BACnet[®] VAV Actuator Installation Procedures

Model #: 2508021

Table of Contents

- Table of Contents 2**
- Revision History 3
- Reference Documents 3
- Limited Warranty 3
- General Information 4**
- Hazard Identification Messages 4
- Description 5
- Application 5
- Component Data 5
- Installation 6**
- Required Tools and Materials 6
- Installing a new BACnet VAV Actuator 6
 - To Install the BACnet VAV Actuator 6
 - To Wire the BACnet VAV Actuator 10

Revision History

IM xxx	Date	Initial release

Reference Documents

Number	Company	Title	Source
OM 1063	McQuay International	VAV Actuator Owners Manual	www.mcquay.com

Limited Warranty

Consult your local McQuay Representative for warranty details. Refer to Form 933-43285Y. To find your local McQuay Representative, go to www.mcquay.com.

Notice

Copyright © 2010 McQuay International, Minneapolis MN. All rights reserved throughout the world. McQuay International reserves the right to change any information contained herein without prior notice. The user is responsible for determining whether this software is appropriate for his or her application.

® ™ The following are tradenames or registered trademarks of their respective companies: BACnet from the American Society of Heating, Refrigerating and Air-Conditioning Engineers, Inc.; Windows from Microsoft Corporation; D-Net, McQuay and MicroTech III from McQuay International.

General Information

This manual contains the information you need to install the BACnet® VAV Actuator on a VAV box.

Hazard Identification Messages

DANGER

Dangers indicate a hazardous situation that will result in death or serious injury if not avoided.

WARNING

Warnings indicate potentially hazardous situations, which can result in property damage, severe personal injury, or death if not avoided.

CAUTION

Cautions indicate potentially hazardous situations, which can result in personal injury or equipment damage if not avoided.

WARNING

Electric shock hazard. Can cause personal injury or equipment damage.

This equipment must be properly grounded. Connections and service to the MicroTech III Chiller Unit Controller must be performed only by personnel knowledgeable in the operation of the equipment being controlled.

CAUTION

Static sensitive components. Can cause equipment damage.

Discharge any static electrical charge by touching the bare metal inside the control panel before performing any service work. Never unplug cables, circuit board terminal blocks, or power plugs while power is applied to the panel.

NOTICE

This equipment generates, uses and can radiate radio frequency energy and, if not installed and used in accordance with this instruction manual, may cause interference to radio communications. It has been tested and found to comply with the limits for a Class A digital device, pursuant to part 15 of the FCC rules. These limits are designed to provide reasonable protection against harmful interference when the equipment is operated in a commercial environment. Operation of this equipment in a residential area is likely to cause harmful interference in which case the user will be required to correct the interference at his or her own expense. **McQuay International disclaims any liability resulting from any interference or for the correction thereof.**

Description

These Installation Instructions describe direct-coupled mounting of the BACnet VAV Actuator, McQuay's Non-spring Return Rotary Electronic Damper Actuator.

Application

This VAV Actuator can be used in control applications 2560 through 2567. For a full description of application specifics please refer to the VAV Actuator Owners Manual (OM 1063).

Component Data

Figure 1 shows the BACnet VAV Actuator. Figure 2 shows the parts associated with the installation of the VAV Actuator.

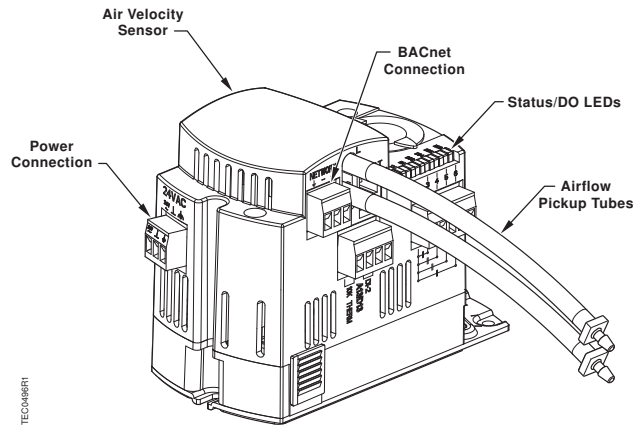

Figure 1. BACnet VAV Actuator.

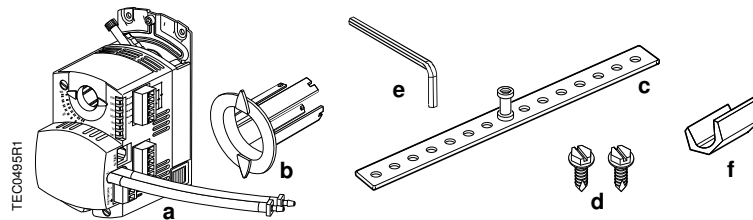

Figure 2. Actuator Parts.

Parts List

- a. Actuator with pre-terminated tubing
- b. Position indicator
- c. Mounting bracket
- d. Self-tapping mounting screws
- e. 4 mm hex key
- f. 3/8-inch shaft adapter (8 to 10 mm shafts)

Installation

The following section describes how to field install a new BACnet VAV Actuator or replace an existing BACnet VAV Actuator on a McQuay VAV unit.

Expected Install Time: 25 minutes

CAUTION

Electrostatic discharge hazard. Can cause equipment damage.

This equipment contains sensitive electronic components that may be damaged by electrostatic discharge from your hands. Before you handle a communications module, you need to touch a grounded object, such as the metal enclosure, in order to discharge the electrostatic potential in your body.

Required Tools and Materials

- 4 mm hex wrench
- Small, flat-blade screwdriver
- 1/4-inch Hex drill/driver set
- Marker or pencil
- Torque Wrench

Installing a new BACnet VAV Actuator

Follow these steps to install a BACnet VAV Actuator on the VAV unit.

To Install the BACnet VAV Actuator

WARNING

Electric shock hazard. Can cause personal injury or equipment damage.

This equipment must be properly grounded. Only personnel knowledgeable in the operation of the equipment being controlled must perform connections and service to the BACnet VAV Actuator.

1. Determine the size of the damper shaft.
 - If the damper shaft is 1/2-inch, proceed to Step 2.

NOTE: The actuator comes with a factory-installed 1/2-inch damper shaft guide.

- If the damper shaft is **5/8-inch**:
 - a. Remove the 1/2-inch shaft guide, Figure 3.

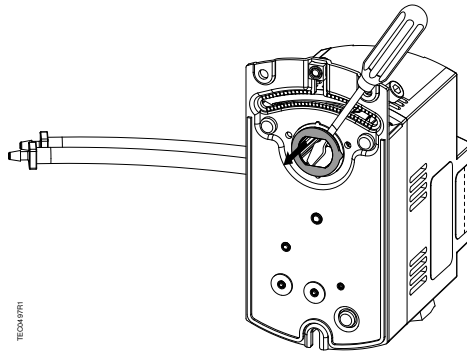

Figure 3. Removing the 1/2-inch Shaft Guide.

- b. Proceed to Step 2.
- If the damper shaft is **3/8-inch**:
 - a. Remove the 1/2-inch shaft guide, Figure 3.
 - b. Use the 3/8-inch adapter, provided in the actuator packaging, Figure 4. Hold the shaft insert so that the raised tabs are inserted last when placing the insert into the back of the actuator.

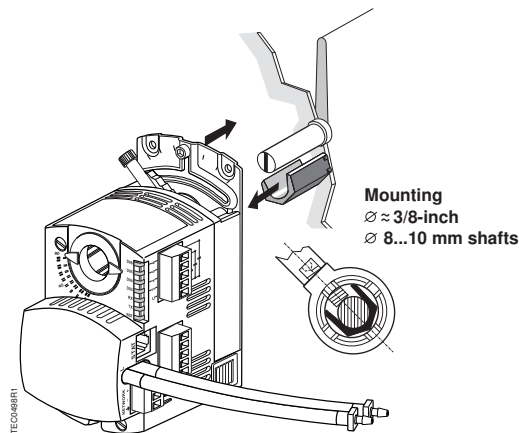

Figure 4. Installing the 3/8-inch Shaft Adapter.

- c. Proceed to Step 2.
- 2. Determine the damper blade rotation, clockwise or counterclockwise to open, Figure 5.

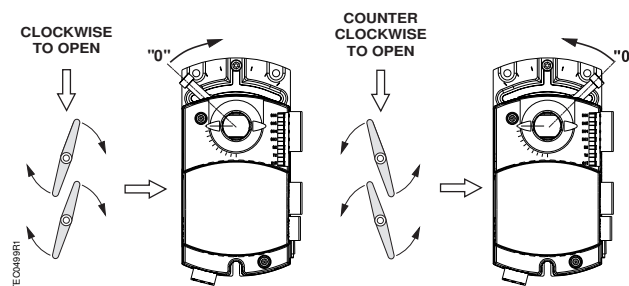

Figure 5. Damper Rotation.

- If the blades will rotate counterclockwise, slide the manual override switch to manual, and move the adjustment lever to the right. Return the switch to automatic, Figure 6.
- If the blades will rotate clockwise, slide the manual override switch to manual, and move the adjustment lever to the left. Return the switch to automatic, Figure 6.

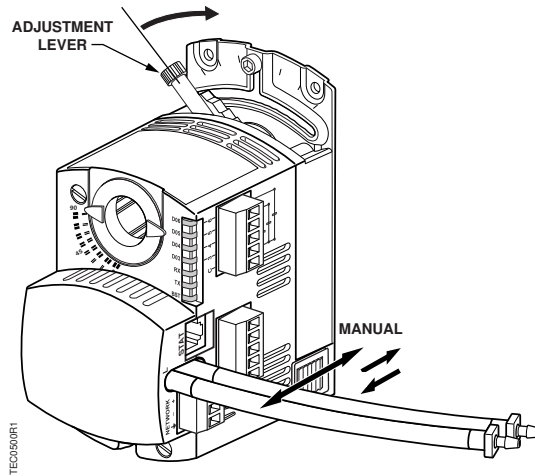

Figure 6. Setting the Direction of Rotation.

3. Close the damper blades, Figure 8.

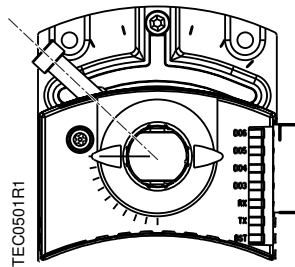

Figure 7. Setscrew in Shaft Hole.

4. Mark the end of the damper shaft with a pencil/marker, Figure 8.
5. Tighten the setscrew until the first thread can be seen in the shaft hole, Figure 7.

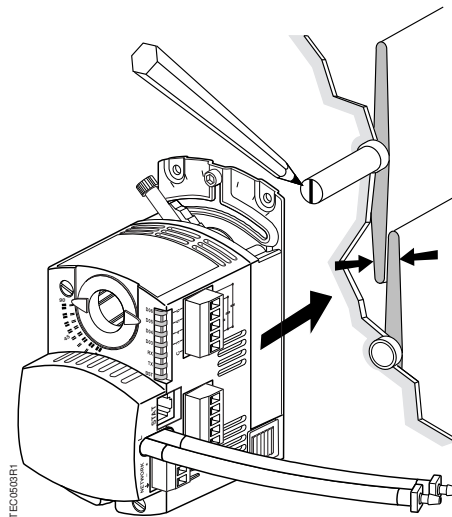

Figure 8. Mounting the Actuator.

6. Mount the actuator on the damper shaft, Figure 8.
7. Install the position indicator, Figure 9.
8. Tighten the adjustment lever to the proper torque listed:

- 70 +/- 5 inch-pounds for solid metal
- 37 +/- 2 inch-pounds for plastic graphite composite (hollow metal shafts require an insert to prevent shaft damage).

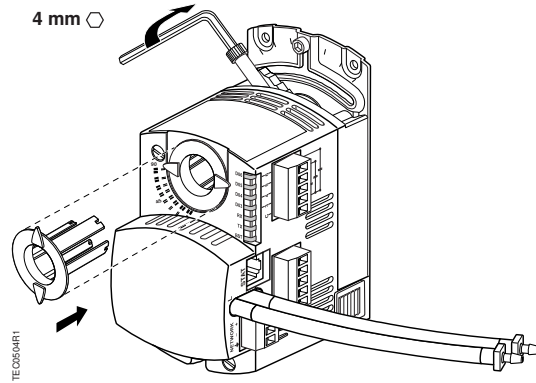

Figure 9. Position Indicator and Adjustment Lever.

9. Attach the mounting bracket, Figure 10.

NOTE: When installing the mounting bracket directly on the ductwork, be sure to position the bracket so that the screws do not obstruct the damper blade movement inside the box.

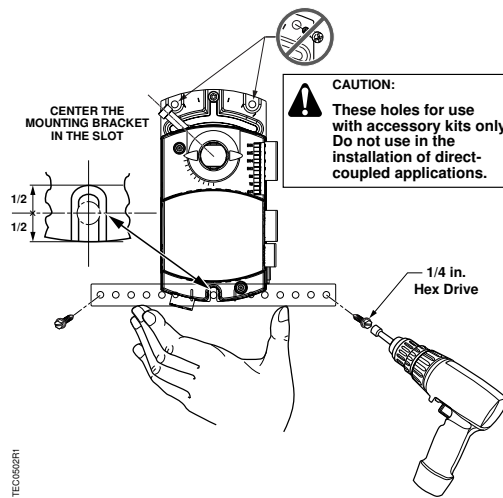

Figure 10. Installing the Mounting Bracket.

10. Connect the airflow tubing for the Differential Pressure Sensor.
 - RED connects to HIGH.
 - BLUE connects to LOW.

To Wire the BACnet VAV Actuator

⚠ WARNING

Electric shock hazard. Can cause personal injury or equipment damage.

This equipment must be properly grounded. Only personnel knowledgeable in the operation of the equipment being controlled must perform connections and service to the BACnet VAV Actuator.

WARNING: Installations requiring CE Conformance

- All wiring for CE rated actuators must be Separated Extra Low Voltage (SELV) or Protective Extra Low Voltage (PELV) per HD384-4-41.
- Use safety-isolating transformers (Class III transformer) per EN 61558. They must be rated for 100% duty cycle.
- Over current protection for supply lines is maximum 4A.

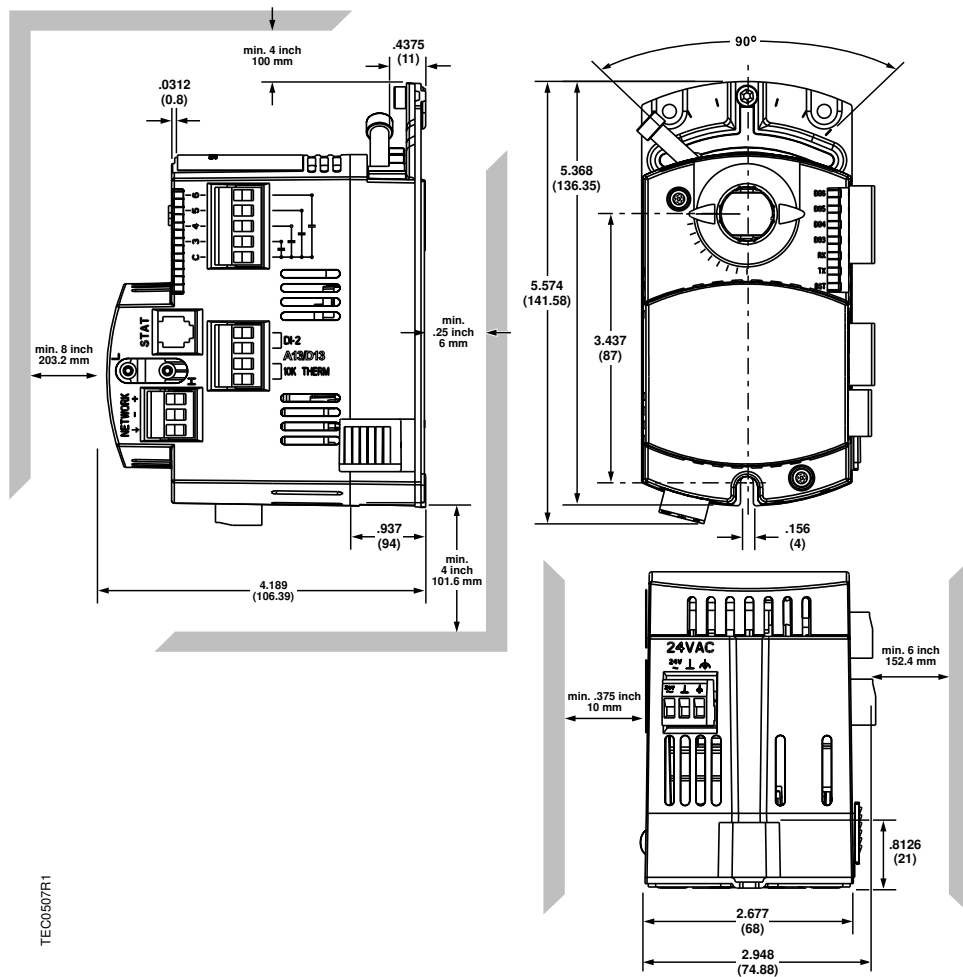

Figure 11. BACnet VAV Actuator Dimensions in Inches (Millimeters).

Wiring Instructions

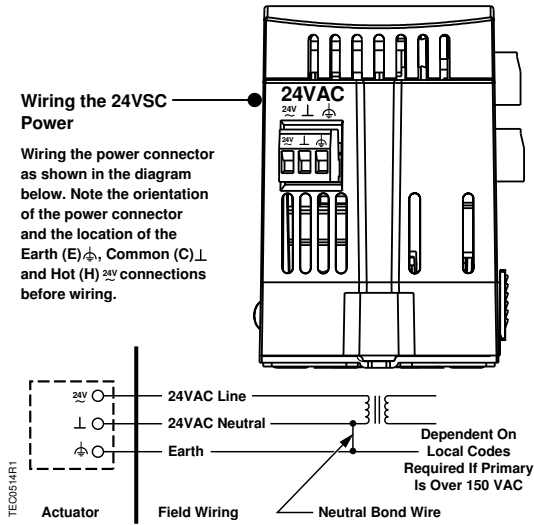

Figure 12. Power Wiring.

Digital Outputs (DO):

The Digital Outputs on the VAV Actuator are dry output Triac type outputs. 24 VAC must be applied to the “C” pin of the DO connector. The side view of the Actuator shows output pin details.

By providing dry output Triac DO's, the application can switch either Phase or Neutral depending on application needs. In a 24 VAC circuit, neutral is determined by which side of the transformer is earth grounded. If neither side is earth grounded (at the transformer) then the 24 VAC is considered a floating (isolated) source.

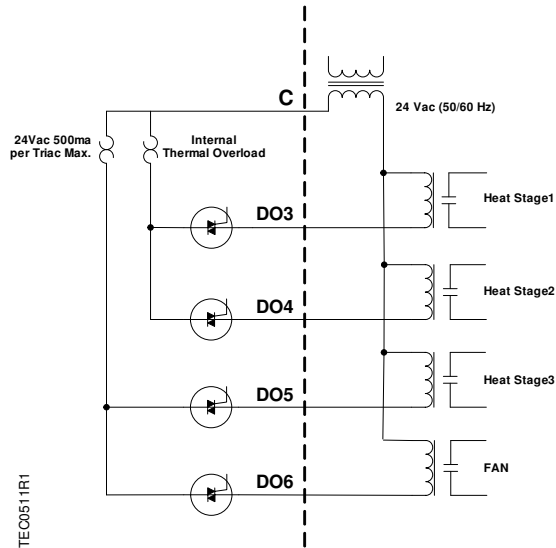
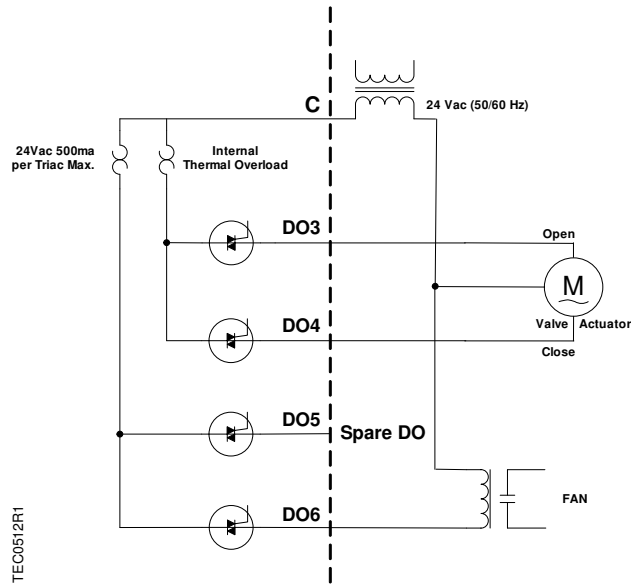
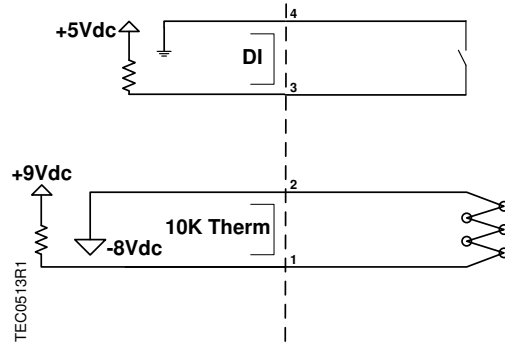

Figure 13. BACnet VAV Actuator with Electric Heat and Fan.



TEC0512R1
Figure 14. BACnet VAV Actuator with Hot Water Reheat, Fan and Spare DO.



TEC0513R1
Figure 15. Wiring for D12/A13.

Wiring DI Common (pin 4) to 10K Thermistor - 8Vdc (pin 2) incorrectly, will cause the actuator to shut down. No damage will occur. When the wiring is corrected the actuator will resume operation.

DO/DI Wiring Diagrams

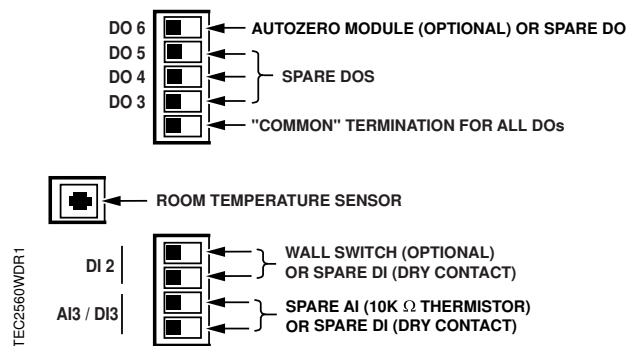

TEC2560WDR1
Figure 16. Application 2560 Wiring Diagram (Cooling Only).

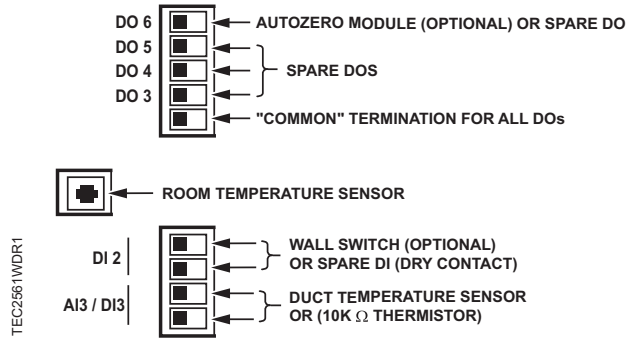

Figure 17. Application 2561 Wiring Diagram (Heating or Cooling).

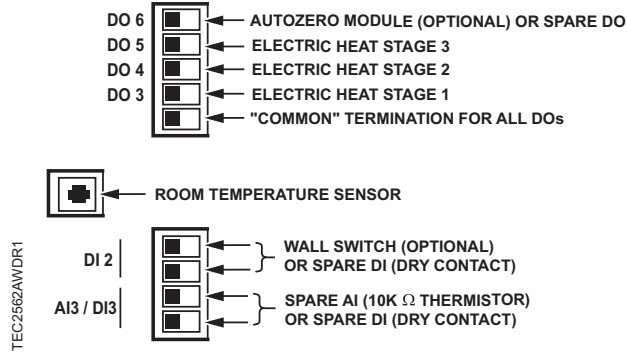

Figure 18. Application 2562 Wiring Diagram (Electric Heat Stages).

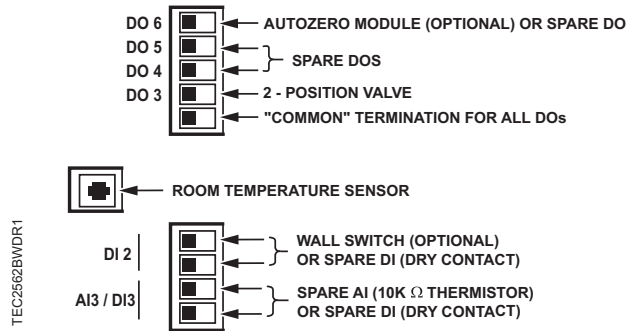

Figure 19. Application 2562 Wiring Diagram (Baseboard Radiation).

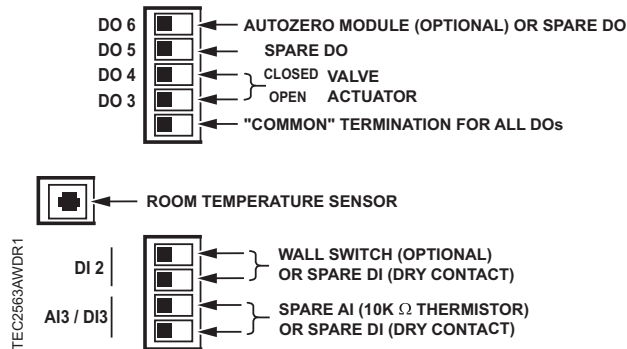

Figure 20. Application 2563 Wiring Diagram (Hot Water Heat and Spare DO).

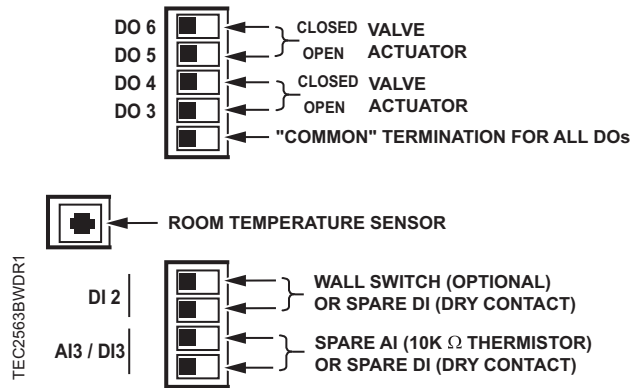

Figure 21. Application 2563 Wiring Diagram (Hot Water Heat 2 Motors).

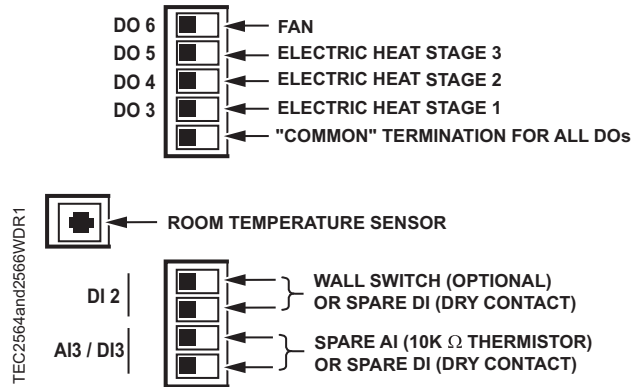

Figure 22. Application 2564/Application 2566 Wiring Diagram (Electric Heat Stage and Series or Parallel Fan).

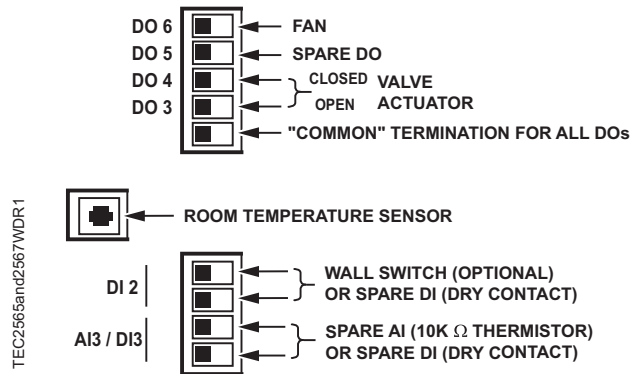

Figure 23. Application 2565/Application 2567 Wiring Diagram (Hot Water Heat and Series or Parallel Fan).

The installation is now complete.