

DAIKIN McQUAY™



Magnitude™ Magnetic Bearing Centrifugal Chillers

Engineered for flexibility and performance™



Daikin McQuay Magnitude™ Chillers



Performance to Save You Million\$ over the Life of the Chiller

The Daikin McQuay Magnitude magnetic bearing centrifugal chiller is the most energy efficient chiller in its size range with part load performance as low as .306 kW/ton IPLV.

This amazing chiller technology has been proven effective in thousands of installations around the world. And it's up to 40% more energy efficient than standard centrifugal chillers, **saving more than \$2 million over the life of the machine.**



Quietest Chiller in Its Size Range

The Magnitude chiller is the quietest chiller in its size range with sound pressure ratings as low as 76 dBA, tested according to AHRI Standard 575. Sound levels will be even lower at reduced loads and non-standard design conditions.

This quiet operation makes the Magnitude ideal for sound sensitive environments such as schools, performance halls, museums, and condominiums.



Magnetic Bearing Compressors

As Reliable As They Are Efficient

- Magnetic bearings eliminate mechanical seals and wear surfaces for longer machine life.
- The simplicity of a direct-drive motor and shaft eliminates gears, slide valves and extra parts to increase reliability.
- VFD designed as an integrated component with the compressor and optimized by digital controls to reduce power consumption while maximizing chiller performance.
- Reduced in-rush current by utilizing a VFD; a gradual soft start that lessens mechanical and thermal stresses leading to increased motor life.
- Onboard digital controls to continuously monitor operating status and provide fault protections.
- Oil-free design eliminates oil management systems for improved compressor and system reliability. The oil-free design also eliminates the possibility of efficiency-robbing oil contamination of heat-transfer surfaces.

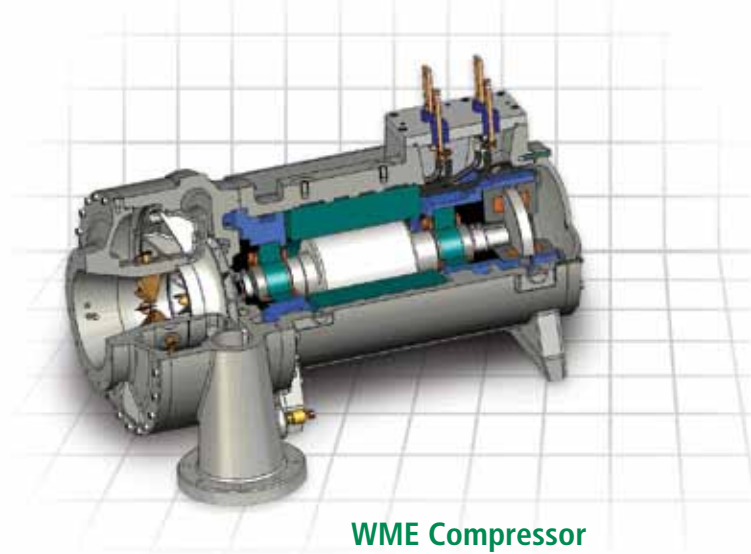

WME Compressor

Why Magnetic Bearing Compressors Are the Right Technology for Today

The frictionless magnetic bearing compressor was developed to improve performance, reliability and reduce service requirements as compared with conventional centrifugal compressor designs.

The magnetic bearing compressor is a single rotating component – the compressor shaft – levitated on a magnetic cushion. This cushion results in the shaft not being in contact with any other part of the compressor while operating. The compressor shaft is kept perfectly aligned in all directions by sensors at each magnetic bearing providing real-time feedback to the digital bearing control system. This cutting edge magnetic bearing technology enables outstanding energy efficiency and reliable, long-life operation.



Power Protection for Long-Term Viability

The compressor's ability to protect itself from low power quality, and to have controlled response in power loss situations, is a feature that enhances long-term compressor viability and reduces downtime. Magnitude chillers can often remain on-line through minor power disturbances and some models meet industry voltage sag immunity standard SEMI F47. In extreme or extended power disruptions, Magnitude compressors are designed to regenerate power from the spinning motor and feed that power back to the bearings and control system. This regenerative power mode allows the compressor shaft to coast down and gently reseat onto touchdown bearings.



Ideal for Retrofit and Replacement

The compact size of the Magnitude™ chiller makes it ideal for retrofit and replacement installations. In addition, the space that would have used for equipment can now be put to more productive use in the facility. Some models can even fit through a standard 36-inch door without disassembling the shells. Even the most challenging access projects can be accommodated using McQuay's factory disassembly option.

Typical 290-ton Unit

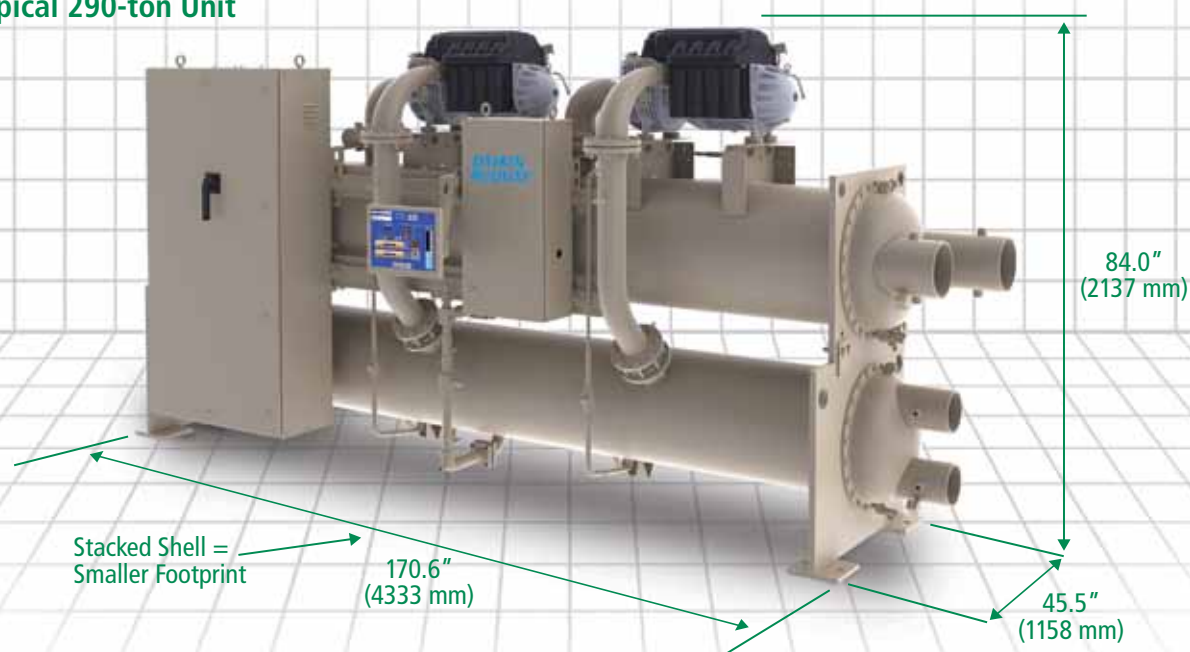

Our Bottom Line For Your Bottom Line

Lowest Total Cost of Ownership

Magnetic bearing centrifugal compressor eliminates the efficiency-robbing friction inherent in traditional centrifugal chillers.

Integrated VFD optimized part load efficiency, a key performance feature since most chillers operate at part load 99% of their life.

Sustainable performance assured for the operating life of the chiller. The positive pressure, oil-free design eliminates performance degradation due to non-condensables and oil contamination of the refrigerant.

Easy integration with our Open Choices™ feature using BACnet®, LonWorks® or Modbus® communications without an expensive gateway panel.

R-134a refrigerant has no ozone depletion potential and no phase-out schedule.

Reduced maintenance costs due to elimination of the oil, oil system, purge system, and shaft seals found in older technology chillers.

Small unit footprint helps the Magnitude™ chiller fit in buildings where space is limited, making it ideal for retrofit projects.

Unmatched unloading with the integrated VFDs since the on-board digital controls reduce compressor speed to match the load.

Low inrush current at startup is ideal for operation with backup or emergency power systems.

Touch screen operator panel is graphically intuitive and easy to use for enhanced operator productivity. Important status and control information is available at a glance or a touch.

Quality assurance and quicker start-up are enhanced by the factory testing of every unit at job site conditions.

Seismic compliance with both IBC seismic certification standards and OSHPD pre-approval.

LEED® points can be earned from the Magnitude chiller's performance in two categories: EAc1, up to 19 points possible, and EAc4, 2 points.



Service and Maintenance Savings

Because the Magnitude magnetic bearing chiller has fewer moving parts, requires no oil, nor oil-circulation equipment, it therefore requires less maintenance and service. With oil removed from the system, maintenance tasks such as oil samples, oil changes, oil filter changes, oil disposal and leaks from shaft seals are eliminated. The results are reduced operational costs and maintenance savings each and every year!

Over the life of the equipment – approximately 20 to 25 years – the total maintenance savings could be significant. Savings an owner would realize depend on maintenance practices, age and efficiency of other equipment, energy prices, etc.

Operator training for maintenance and operation of Magnitude chillers are available from McQuay. Visit the Training page at www.mcquay.com for details.





What the Owners of Daikin McQuay Magnitude™ Chillers Say About Their Units

Johnson County Office Building in Olathe, Kansas

We save **57% on energy costs** compared to a similar county office building down the road. And with the high performance McQuay frictionless chiller as part of our system, we earned **LEED® Gold certification** from the U.S. Green Building Council.

Neil Angrisano, AIA, Deputy Facility Manager for Johnson County



© Photography by Brad Feinkopf

Sarasota Bradenton International Airport Sarasota, Florida

The 500-ton variable speed magnetic bearing chillers will provide the airport with an electrical consumption savings estimated to be 30%. The new chiller technology also extends the chiller life, reduces annual maintenance costs, improves controls of the chiller tower operation, and is LEED® qualified.

Robert Mattingly, Vice President of Operations and Maintenance



Northbrook Junior High School in Northbrook, Illinois

We were sold on the **quiet operation** of the chillers because the plant is located next to three classrooms. The 18% reduction in energy costs with the McQuay frictionless chillers helped us earn an **Energy Star® School** rating from the U. S. EPA after our mechanical system modernization.

Russ Jensen, Director of Buildings and Grounds for Northbrook School District 28

McNamara Alumni Center at the University of Minnesota in Minneapolis

The **compact design** of the chiller worked in our very tight design. Because the unit is so **quiet** we could avoid installing a housekeeping pad typically used to isolate sound, thus greatly reducing the weight and physical footprint.

Jon McCombs, Operations Manager, McNamara Alumni Center





Make it a Complete System for Optimum System Performance and Reliability

STEP 1

Choose a Daikin McQuay Magnitude™ Chiller



100 to 400-ton Magnitude™ Chiller
Water-Cooled Chiller



400 to 700-ton Magnitude™ Chiller
Water-Cooled Chiller

STEP 2

Choose a McQuay Air Handler or Terminal Unit



Vision™ Indoor Air Handler
900 to 100,000 cfm



Skyline™ Outdoor Air Handler
900 to 65,000 cfm



Destiny™ Indoor Air Handler
600 to 15,000 cfm



RoofPak™ Outdoor Air Handler
4000 to 50,000 cfm



Unit Ventilators
750 to 2,000 cfm



Fan Coil Units
200 to 3,000 cfm

McQuay[®]
International

a member of **DAIKIN** group

800.432.1342
www.mcquay.com

™® The following are tradenames or registered trademarks of their respective companies: BACnet from ASHRAE; Modbus from Schneider Electric Ltd; MicroTech III, Open Choices, from McQuay International; LONMARK, LonTalk, and LONWORKS are managed, granted and used by LONMARK International under a license granted by Echelon Corporation.

©2011 McQuay International
A/SP 31-290 (06/11)